

Vertical Lifting Clamp IP10S

Product information



The IP10S vertical lifting clamps are used for the lifting, turning, moving or vertical transfer of **stainless steel** sheet, plates, or fabrications, from horizontal to vertical and down to horizontal (180°) as needed. Usually used as a single point pick or when used with a spreader beam with multiple vertical drop lines. Available in a variety of models:

- IP10 - Standard clamp for materials with a surface hardness to 363HV10 (345 HB).
- IP10J - Larger jaw opening.
- IP10S - For use with Stainless Steel material.
- IP10H - For use with materials with a surface hardness to 472HV10 (450 HB).

Features:

- Available in capacities of 0.5 thru 12 metric tons
- Higher Working Load Limits are available upon request.
- Wide variety of jaw openings available: 0 to 54 mm.
- Welded alloy steel body for strength and smaller size. Forged alloy components, where required.
- Individually Proof Tested to 2 times the Working Load Limit with certification.
- User manual and test certificate included with each clamp.
- Full 180° turning range for material transfer, turning or moving.
- Lock open, lock closed ability with latch for pretension on material and then release of material.
- Maintenance and repair kits are available.
- All sizes are RFID EQUIPPED.

... [Read more](#)

Material: Alloy Steel. Pivot & cam stainless steel

Marking: According to standard, CE-marked, WLL, Logo, Jaw opening, Serial number

Temperature range: -40°C up to +100°C

Standard: EN 13155

Warning: A minimum load of 10% of the WLL is required.

Vertical Lifting Clamp IP10S

Blueprint

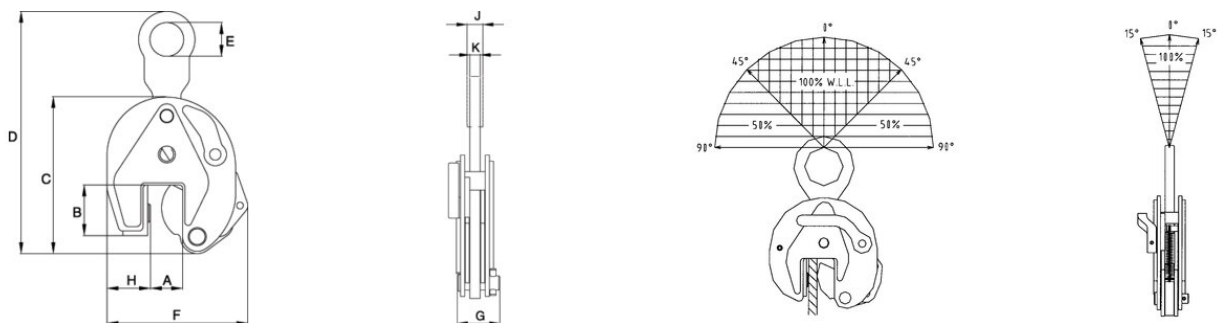

Lifting table

Part code	WLL ton	Jaw width mm	Model	A mm	B mm	C mm	D mm	E mm	F mm	G mm	H mm	J mm	K mm	Weight kg
502100050160370	0.5	0-16	0.5-IP10S	0-16	44	130	203	40	115	42	28	11	11	1.8
502100100200370	1	0-20	1-IP10S	0-20	45	139	212	40	127	42	38	11	11	2.2
502100200350370	2	0-35	2-IP10S	0-35	78	201	330	70	188	64	55	16	16	7.6
502100300400370	3	0-40	3-IP10S	0-40	100	253	434	75	222	78	60	20	20	13.8
502100450400370	4.5	0-40	4.5-IP10S	0-40	100	253	434	75	227	82	65	20	20	15
502100600500370	6	0-50	6-IP10S	0-50	126	302	517	80	292	84	95	20	20	23.5
502100900500370	9	0-50	9-IP10S	0-50	126	325	544	80	310	94	104	25	25	27.5
502101200540370	12	0-54	12-IP10S	0-54	-	-	-	-	-	-	-	-	-	49