



GB Instruction for use
SE Bruksanvisning



POWERTEX Lever Hoist model PLH-S1

POWERTEX Lever Hoist PLH-S1 0,25 – 9 ton Instruction for use (GB) (Original instructions)

Read through these user instructions before using the lever hoist. Improper operation may lead to hazardous situations.

General safety provisions

- Check the function of the lever hoist before use. See “Daily checks” on page 3.
- Do not exceed the maximum load.
- Full function of the brake system can only be secured at a minimum load of 30 kg for capacities (WLL) up to 1 ton, and for capacities (WLL) above 1 ton, the minimum load to be greater than 3% of the rated capacity (WLL).
- Handle the lever hoist with care. Do not throw the hoist about or let it fall to the ground.
- Do not use the lever hoist for welding work where it is exposed to welding spatter or current.
- The lever hoist block must not be used for lifting persons.

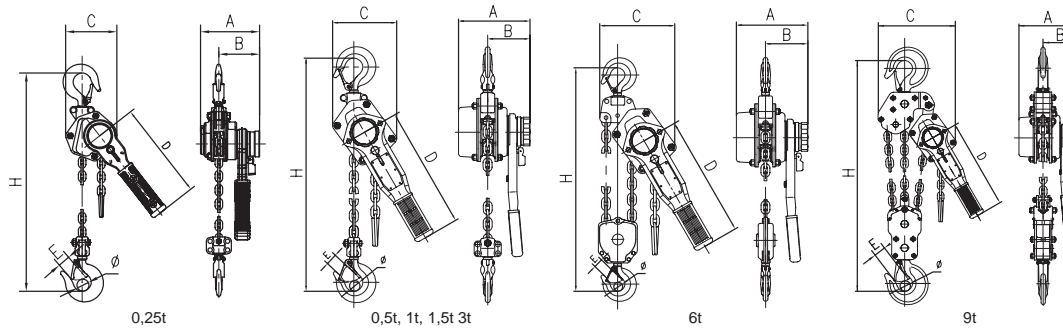

Fig. 1 Dimensioned sketch

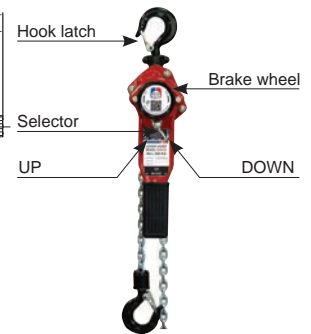

Fig. 2 Description

Technical data (See Fig. 1 dimensioned sketch)

Model	PLH-S1	PLH-S1	PLH-S1	PLH-S1	PLH-S1	PLH-S1	PLH-S1
Max. load tonnes	0,25	0,5	1	1,5	3	6	9
Lifting height m	1	1,5	1,5	1,5	1,5	1,5	1,5
Number of falls	1	1	1	1	1	2	3
Force on lever pã daN (kp)	12	25	29	32	36	37	37
Load chain mm	4x12	5x15	6x18	7,1x21	10x28	10x28	10x28
Dimension A mm	100	150	156	186	208	208	208
Dimension B mm	71	90	95	112	120	120	120
Dimension C mm	85	118	138	145	198	230	338
Dimension D mm	168	253	278	378	418	418	418
Dimension Ø mm	18	20	25	30	36	43	87
Dimension E mm	20	22	26	29	37	43	50
Dimension H min mm	250	310	340	400	520	640	730
Weight kg	2,2	5,3	8,0	11,1	20,5	29,5	50,5

Safety factor : 4:1.

Static test coefficient: WLL x 1,5.

Generally according to EN 13157.

Function (See Fig. 2)

Make sure the chain is unloaded and set the selector to neutral position (N). Pull the chain through by hand to the desired position.

Pulling through the unloaded chain (see Fig. 2)

Make sure the chain is unloaded and set the selector to neutral position (N). Pull the chain through by hand to the desired position.



Warning! If the selector is in position UP or DOWN when the chain is pulled, the lever may rotate like a propeller, which could be dangerous.



Warning! If the lever hoist is used on a load which is too light, the brake function will not engage. The load must be at least 3% of maximum load. For example a minimum load of 30 kg is necessary to engage the brake on a 1 tonne hoist. For lightloads choose a smaller lever hoist.

If it proves impossible to pull the chain through despite the selector being in neutral, it may be necessary to release the brake first, by turning the brake wheel anti-clockwise. If this does not help, set the selector to position DOWN, load the chain slightly and jerk the lever in clockwise direction. Then try again without load but with the selector in neutral.

Suspension of lever hoist

Make sure the hoist is suspended from an eye, shackle or similar with sufficient bearing capacity. With the chain tightened, both hooks must be in line (Fig. 3a).



NB! Neither hoist, hooks nor chain may be subjected to bending stresses (Figs. 3b and c and Fig. 4).

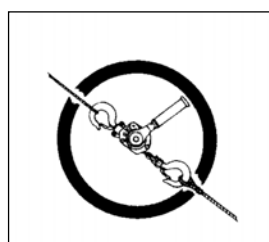

Fig 3 a

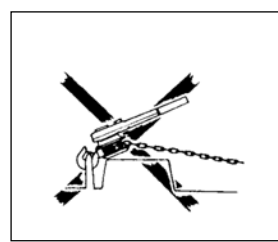

Fig 3 b

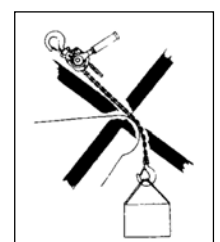

Fig 3 c

Attachment of loads

Check the equipment well before use. Improper attachment of loads can be highly dangerous (see Figs. 4 a–e).



Only use straps and slings of sufficient load capacity. Make sure the load is not anchored to the floor/ground or is otherwise fixed before making the lift.

Lifting/pulling

With the selector in position UP, operate the lever to tighten the chain. Check for safety before lifting the load to the desired position. If the load is too light to be lifted, hold onto the brake wheel so you hear the snapping sound. You will then be able to lift the load with just one hand. If the lever is released while lifting, the load will be held in its current position by the reaction brake. The lever hoist can also be used for pulling and fixing loads.



Fig 4 a

The sling is applying load to the hook tip!

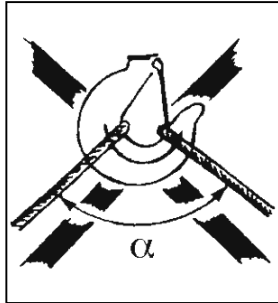

Fig 4 b

Excessive top angle on sling!
 α maks. 60°



Fig 4 c

Hook latch obstructed!

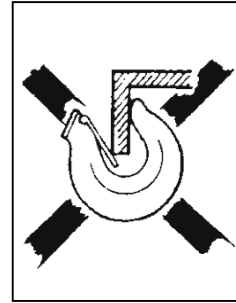

Fig 4 d

Hook tip subject to additional bending stress!

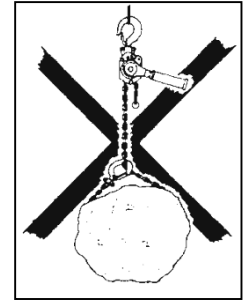

Fig 4 e

Load chain must not be used as a sling!

Further safety precautions

- Never lengthen the lifting lever with a pipe or similar. Use only hand power on the lever. If the load seems too heavy, use a bigger lever hoist or reduce the load.
- Make sure no-one stands beneath a hanging load.
- Do not raise or lower so far that the load hook or the stop eye hits the block housing.
- Do not set the selector to neutral under load.
- The block must not be subjected to dynamic stresses, for example where a load connected to the block is launched from a height.
- Do not leave a block with a suspended load unattended.

Lowering

With the selector in DOWN position, operate the lever to lower the load. Wait until the chain has been completely freed of load before moving the selector to Neutral (N) to rapidly pull out the chain. (See "Pulling through the unloaded chain" page 2).

Multiple lifting

Multiple lifting presents special risks. This is when two or perhaps more hoists are used simultaneously for the same load. Danger to persons and material damage can arise due to dynamic stresses and uneven load distribution causing individual hoists to become overloaded. A competent person with experience in multiple lifting must therefore supervise this type of lifting tasks.

The total weight of the target object and its load distribution must be known or calculated.

For a variety of reasons, the centre of gravity can be difficult to determine, and thus so will the distribution of the load each hoist must bear. In cases where heavy, bulky loads must be handled and it is not possible to estimate all factors correctly, the max working load limit (WLL) of each hoist must be reduced by at least 25%.

Daily checks

After every working day on which the lever hoist has been used, the following should be checked:

- Is the lever hoist deformed or otherwise damaged? Are any parts missing?
- Is any deformation or other damage visible on the suspension device (eye, shackle, bolt or similar)?
- Are the hooks intact or have any hooks opened? Are the hook latches correct and functional?
- The selector must work without problems.
- Wipe down the lever hoist and oil the chain as required.
- The chain must be undamaged, i.e. no signs of wear and no deformed or otherwise damaged links.
- The chain must not be kinked or twisted. With 2-fall lever hoists (6 t), there is a risk of the chain twisting if the bottom hook assembly ends up looped through the chain sling – usually during refitting or moving the hoist between work stations. See Fig 5.
- The chain stop must free of deformation or other damage.
- The brake function must be intact.

In the event of faults or failures, the hoist must be repaired and carefully checked by a specialist before reuse.

Continuous maintenance - lubrication

Oil the hook latches and bearings. Grease the pawl and ratchet and also the gear. Lubrication must be sparingly and carefully applied so no grease gets on the brake disk. Oil the chain for longer life.

Periodic checks

Periodic checks are normally carried out yearly to detect and remedy any faults. If required (e.g. high frequency of use), more frequent checks may be carried out. See "Checklist for periodic checks". Measure hooks and chain to detect any changes in shape.

Hook checks (see fig 6 and Table 2)

Opening dimension I on the hooks is important. A hook with too large a maximum dimension has been exposed to overloading or overheating. It therefore does not have the necessary load capacity. The hooks may also have been exposed to long-term wear (dimension K).

Hooks must be discarded and replaced if:

- the maximum I value is exceeded (according to Table 2)
- the minimum K value falls short (according to Table 2)
- the hook is cracked, deformed or otherwise damaged.

Defective hooks must be replaced before using the lever hoist again!

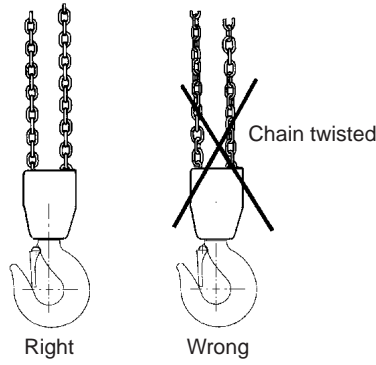

Fig 5

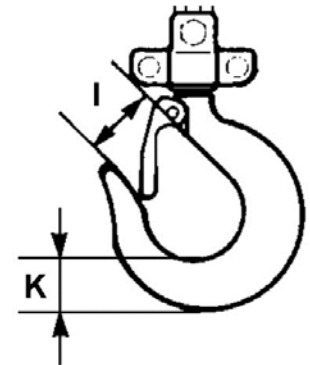

Fig 6

Table 2 Hook dimensions

Max. load tonnes	0,25	0,5	1	1,5	3	6	9
Model	PLH-S1	PLH-S1	PLH-S1	PLH-S1	PLH-S1	PLH-S1	PLH-S1
Dimension I nominal mm	24	25,5	30	33	41,5	47	61
Dimension I, max. mm	26,4	28,0	33	36,3	45,6	51,7	67
Dimension K nominal mm	15	19	25	30	39	44,5	69
Dimension K min mm	13,5	17,1	22,5	27,0	35,1	40,0	62

Check measurement of chain (See Fig. 7 and table 3)

Inspect the chain over its whole length to detect any deformed or otherwise damaged links. Make a check measurement of suspect links. Measure the worn areas. Also, every 300 mm (normally), take check measurements of the internal length of 5 links (pitch dimension 5xP according to Table 3).

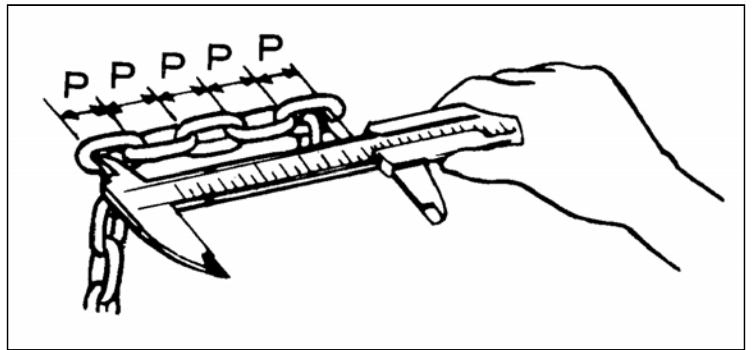

Fig 7 Checking chain dimensions

Table 3 Chain dimensions

Max. load tonnes	0,25	0,5	1	1,5	3	6	9
Model	PLH-S1	PLH-S1	PLH-S1	PLH-S1	PLH-S1	PLH-S1	PLH-S1
Link diameter nominal mm	4,0	5,0	6,0	7,1	10,0	10,0	10,0
Link diameter min. mm	3,6	4,5	5,4	6,4	9,0	9,0	9,0
Pitch dimension (5xP) nominal mm	60,0	75,0	90,0	105,0	140,0	140,0	140,0
Pitch dimension (5xP) max. mm	61,8	77,2	92,7	108,1	144,2	144,2	144,2

The chain must be discarded and replaced if:

- cracks are detected on any link
- any link is deformed or otherwise damaged
- The minimum value of any link's diameter falls short
- the maximum value of the pitch dimension is exceeded at any point
- the chain is damaged by overheating or has been affected by weld splatter

Chains must **not** be repaired – they must be replaced by a new original chain. If it is desired to lengthen the chain, it must be replaced by a new and longer chain.

Replacement of the chain shall be performed professionally by an authorized repairer and the chain must meet the requirements stated in the standard EN 818-7 from the following manufacturers: Chaineries Limousines, Pewag, Thiele or Rud.

Repairs

The lever hoist must not be modified. Repairs must be carried out by specialists. Damaged parts must only be replaced with original Powertex spare parts. Order them through your dealer.

Checklist for periodic checks (normally yearly – more frequently if necessary)

Daily	Yearly	Inspection items	Inspection method	Note
Labels				
X	X	Rating plate	Visual	If the plate is hard to read - replace it
Function				
X	X	Raising and lowering function	Test without load	A low snapping noise should be audible
-	X	Raising and lowering function	Try with 125% of rated load over a distance of min. 300 mm.	The lever runs easily. Load chain sprocket and chain work well together Brake works. The chain does not twist or tangle Hand pulling on the lever feels even
X	X	Selector	Operation	Easy to reset
X	X	Neutral	Operation	Function
Hooks				
X -	X	Hook opening	Visual Measurement	Looks normal See Fig. 6 and Table 2
X		Deformation	Visual	No visible deformation
X	X	Hook bearing	Visual	No abnormal play
X -	X	Wear, cracks, deformation and corrosion	Visual Measurement	No visible damage See Fig. 6 and Table 2
X	X	Hook latches	Visual	Works, spring entire
Chain				
X -	X	Pitch	Visual Measurement	Looks normal Measure in case of doubt See Fig. 7 and Table 3
X -	X	Wear	Visual Measurement	Looks problem-free. Measure in case of doubt See Fig. 7 and Table 3
X	X	Deformation	Visual	No deformation. Measure in case of doubt
X	X	Cracks etc.	Visual	No cracks
X	X	Rust	Visual	No rust
Housing				
X	X	Housing	Visual	No deformation and no rust
-	X	Operating lever	Visual	No deformation
-	X	Load chain sprocket	Visual after dismantling	No serious wear or cracks. No fractures or deformation
-	X	Bearings	Visual, testing	No damage, smooth running
-	X	Gears	Visual after dismantling	No serious wear or fractures
X	X	Chain stopstop	Visual	Must be free of deformation
Screws				
X	X	Screws, nuts, rivets, cotters etc.	Visual	Must not be missing. Tighten loose items. Replace as necessary
Brake				
-	X	Brake disk	Visual	Replace if worn
-	X	Brake screw	Visual	No serious wear
-	X	Pawl and ratchet.	Visual	Replace worn parts. Carefully lubricate with grease

POWERTEX Spaklyftblock PLH-S1 0,25 – 9 ton

Bruksanvisning (SE)

Läs igenom denna bruksanvisning innan lyftblocket tas i bruk. Felaktig användning kan innebära fara!

Allmänna säkerhetsanvisningar

- Kontrollera spaklyftblockets funktion före användning. Se: "Daglig kontroll" sidan 7.
- Belasta inte med mer än maxlasten.
- Full funktion av bromssystemet kan bara säkras vid en minsta last av på 30 kg för en kapacitet (WLL) upptill 1 ton. För kapacitet (WLL) över 1 ton skall minsta lasten vara mera än 3% av nominell kapacitet (WLL) Hantera spaklyftblocket varsamt. Kasta inte och släpa inte blocket.
- Använd inte spaklyftblocket vid svetsningsarbeten så att det kan bli utsatt för svetsstänk eller svetsström.
- Spaklyftblocket får ej användas för personlyft.

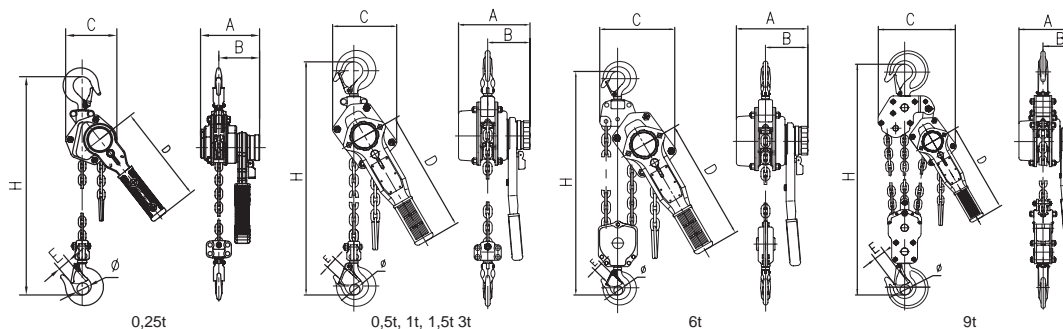

Fig 1 Måttuppgifter

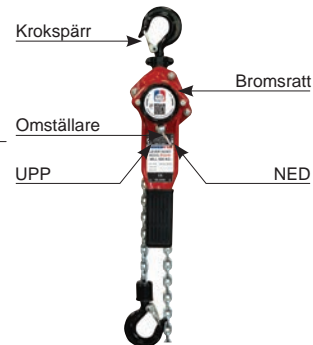

Fig 2 Benämning

Tekniska data, Tabell 1 (Se fig 1 Måttskiss)

Modell	PLH-S1	PLH-S1	PLH-S1	PLH-S1	PLH-S1	PLH-S1	PLH-S1
Maxlast ton	0,25	0,5	1	1,5	3	6	9
Standard lyfthöjd m	1	1,5	1,5	1,5	1,5	1,5	1,5
Antal lyftparter	1	1	1	1	1	2	3
Kraft på spaken daN (kp)	12	25	29	32	36	37	37
Lastkätting mm	4x12	5x15	6x18	7,1x21	10x28	10x28	10x28
Mått A mm	100	150	156	186	208	208	208
Mått B mm	71	90	95	112	120	120	120
Mått C mm	85	118	138	145	198	230	338
Mått D mm	168	253	278	378	418	418	418
Mått Ø mm	18	20	25	30	36	43	87
Mått E mm	20	22	26	29	37	43	50
Mått H min mm	250	310	340	400	520	640	730
Weight kg	2,2	5,3	8,0	11,1	20,5	29,5	50,5

Säkerhetsfaktor: 4:1.

Statisk provkoefficient: WLL x 1,5.

Generellt i överensstämmelse med EN 13157.

Funktion (se fig 2)

Med spaken kan en last lyftas eller sänkas beroende på omställarens läge för UPP respektive NED (U / D). Lasten hänger kvar även om man släpper spaken tack vare en effektiv lasttrycksbroms. Obelastad kätting kan dras igenom blocket med omställaren i friläge (N) (se vidare nedan).

Genomdragning av obelastad kätting (se fig 2)

Se till att kättingen är obelastad och ställ omställaren i friläge (N). Dra igenom kättingen för hand till önskat läge.



Varning! Om omställaren är i läge UPP eller NED och man drar i kättingen kan spaken rotera som en propeller vilket innebär fara.



Varning! Om man använder spaklyftblocket för en för lätt last träder inte bromsfunktionen in. Minst 3% av maxlasten behövs. Exempelvis behövs minst 30 kg last för att 1-tons-blockets broms skall träda in. Vid lätta laster välj ett mindre spaklyftblock!

Om det inte går att dra igenom kättingen trots att omställaren är i friläget kan man först behöva lossa bromsen genom att vrida bromsratten moturs. Om det inte hjälper ställ omställaren i läge NED, belasta kättingen något och ge spaken en knyck moturs. Gör sedan ett nytt försök utan last med omställaren i friläge.

Upphängning av spaklyftblocket

Se till att blocket hängs upp i ögla, schackel eller dylikt som har tillräcklig bärighet. När kättingen stramats upp skall de båda krokarna ligga i linje med varandra (fig 3 a).



OBS! Varken block, krokar eller kätting får utsättas för böjpåkänning (fig 3 b och c samt 4).

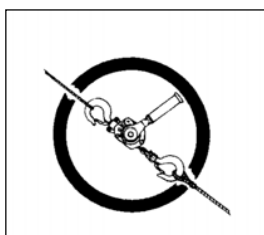

Fig 3 a



Fig 3 b

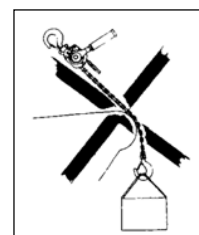

Fig 3 c

Lastkoppling

Kontrollera utrustningen i god tid före användning. Felaktig lastkoppling kan vara mycket farlig (se fig 4 a–e).



Använd endast stroppar och sling med tillräcklig bärighet. Se till att lasten inte är förankrad i golvet / marken eller fast på annat sätt när lyftet skall ske.

Lyft/drag

Med omställaren i läge UPP baxas med spaken så att kättingen stramas upp. Kontrollera säkerheten innan lasten lyfts till önskat läge. Om lasten är för lätt för att baxas, håll emot bromsratten så att man hör snäppandet. Därefter kan man baxa med bara ena handen. Om man vid lyft last släpper spaken hålls lasten kvar i sitt läge av lasttrycksbromsen. Spaklyftblocket kan även användas för drag och fastspänning av gods.



Fig 4 a
Slinget belastar
krokspetsen!

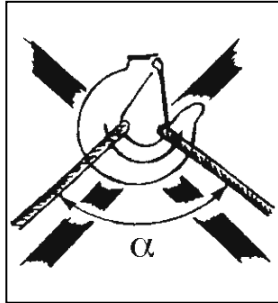

Fig 4 b
För stor toppvinkel
på slinget!
 α max 60°

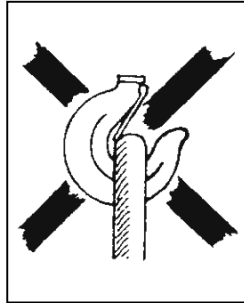

Fig 4 c
Krokspärren blockerad!

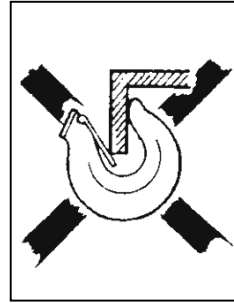

Fig 4 d
Krokspetsen dessutom
utsatt för böjpåkänning!

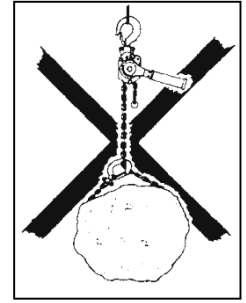

Fig 4 e
Lastkättingen får ej
användas som sling!

Ytterligare säkerhetsåtgärder

- Förläng aldrig baxningsspaken med rör eller dylikt. Endast handkraft får användas på spaken! Om det känns för tungt välj ett större spaklyftblock eller reducera lasten.
- Se till att ingen befinner sig under hängande last!
- Lyft och sänk inte för långt så att lastkroken respektive stoppögla går emot blockets hus.
- Ställ inte omställaren i friläge under belastning
- Blocket får inte utsättas för dynamisk påkänning exempelvis genom att en till blocket kopplad last knuffas ut från en höjd.
- Lämna inte blocket med hängande last oöversatt.

Sänk

Med omställaren i läge NED baxas med spaken och lasten sänks. Inte förrän kättingen blivit helt avlastad får omställaren föras till friläget (N) för snabb genomdragnings av kättingen. (Se "Genomdragnings av obelastad kätting" sidan 6).

Lyft med flera lyftanordningar

Lyft med flera lyftanordningar medför särskilda risker. Med detta avses att två eller flera lyftanordningar används samtidigt för samma last. Fara för personer samt materiella skador kan uppstå på grund av dynamisk belastning och ojämn lastfördelning som leder till att enskilda lyftanordningar överbelastas. En kvalificerad person med erfarenhet av lyft med flera lyftanordningar måste därför övervaka denna typ av lyftarbeten. Totalvikten för objektet som ska lyftas och dess lastfördelning måste vara kända eller beräknas. Tyngdpunkten kan av flera olika skäl vara svår att fastställa och därmed även fördelningen av lasten som varje lyftanordning måste bära. Om tung och skrymmande last måste hanteras och det inte är möjligt att bedöma alla faktorer korrekt måste den högsta tillåtna belastningen (WLL) för varje lyftanordning minskas med minst 25%.

Daglig kontroll

Efter varje arbetsdag som spaklyftblocket använts kontrolleras följande

- Har spaklyftblocket blivit deformerat eller fått andra skador? Saknas någon eller några delar?
- Syns det någon deformation eller annan skada på upphängningsanordningen (ögla, schackel, bult eller dylikt)?
- Är krokarna intakta eller har någon krok öppnats? Är krokspärrarna felfria och funktionsdugliga?
- Omställaren skall fungera felfritt.
- Spaklyftblocket torkas av och kättingen anoljas vid behov.
- Kättingen skall vara oskadad d v s ej sliten eller ha deformerade eller på annat sätt skadade länkar.
- Kättingen får inte ha kinkar och ej heller vara vriden. För 2-partigt spaklyftblock (6 ton) finns risken att kättingen blir vriden genom att underblocket råkar bli vänt igenom kättingslingan – oftast vid ommontering eller flyttning av lyftblocket mellan olika arbetsställen. Se fig 5.
- Kättingstoppet skall vara utan deformation och andra skador.
- Bromsfunktionen skall vara intakt.

I händelse av fel eller brister skall blocket repareras och noggrant kontrolleras av fackman innan det tas i bruk igen.

Fortlöpande underhåll – smörjning

Anolja krokspärrar och -lagringar. Spärrhake och -hjul samt växel smörjs med fett. Smörjning skall ske sparsamt och försiktigt så att det inte kommer smörjmedel på bromsskivan. Kättingen anoljas för längre livslängd.

Regelbunden kontroll

Regelbunden kontroll utförs normalt årligen för att eventuella brister skall upptäckas och åtgärdas. Vid behov (t ex hög användningsfrekvens) utförs tätare kontroll. Se "Checklista för regelbunden kontroll". Krokar och kätting mäts för att upptäcka eventuella formförändringar.

Krokkontroll (se fig 6 och tabell 2)

Krokarnas öppningsmått I är viktigt. Det är invändiga krokmåttet exklusive krokspärren. En krok med för stort maxmått har varit utsatt för överbelastning eller upphettning. Den har därför inte tillräcklig bärighet. Krokarna kan även ha blivit utsatta för långvarigt slitage (mått K).

Defekt krok skall bytas innan spaklyftblocket används igen!

En krok skall skrotas och bytas mot ny om:

- I-måttets maxvärde överskrids (enligt tabell 2)
- K-måttets minvärde underskrids (enligt tabell 2)
- Kroken har någon spricka, blivit deformerad eller på annat sätt skadad.

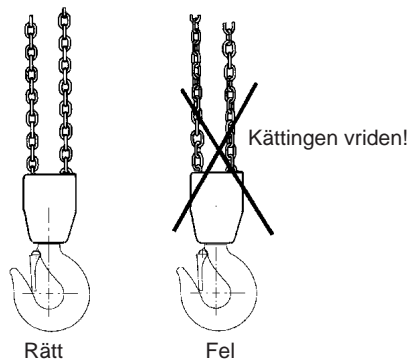

Fig 5

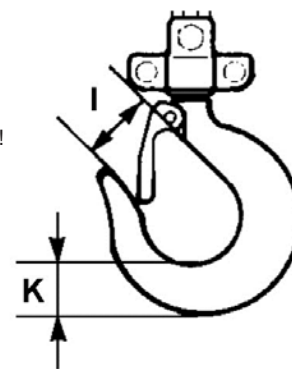

Fig 6

Tabell 2 Lastkrok

Maxlast ton	0,25	0,5	1	1,5	3	6	9
För modell	PLH-S1	PLH-S1	PLH-S1	PLH-S1	PLH-S1	PLH-S1	PLH-S1
Mått I nominellt mm	24	25,5	30	33	41,5	47	61
Mått I max mm	26,4	28,0	33	36,3	45,6	51,7	67
Mått K nominellt mm	15	19	25	30	39	44,5	69
Mått K min mm	13,5	17,1	22,5	27,0	35,1	40,0	62

Kontroll av lastkätting (se fig 7 och tabell 3)

Granska kättingen utefter hela längden för att upptäcka eventuella deformerade eller på annat sätt skadade länkar. Misstänkta länkar kontrollmätts. Mät på slitställena. Kontrollmät även varje 300 mm (i normalfall) den invändiga längden av 5 länkar (delningsmättet 5xP – enligt tabell 3).

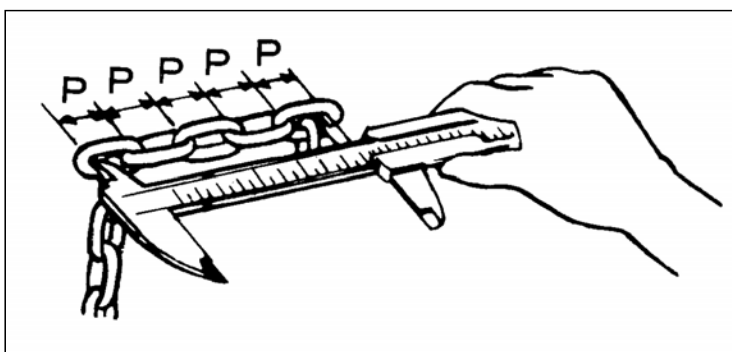

Fig 7 Kontrollmätning av kättingen

Tabell 3 Kättingmått

Makslast ton	0,25	0,5	1	1,5	3	6	9
För modell	PLH-S1	PLH-S1	PLH-S1	PLH-S1	PLH-S1	PLH-S1	PLH-S1
Länkdiameter nominellt mm	4,0	5,0	6,0	7,1	10,0	10,0	10,0
Länkdiameter min mm	3,6	4,5	5,4	6,4	9,0	9,0	9,0
Delningsmått (5xP) nom mm	60,0	75,0	90,0	105,0	140,0	140,0	140,0
Delningsmått (5xP) max mm	61,8	77,2	92,7	108,1	144,2	144,2	144,2

Kättingen skall skrotas och bytas ut mot ny om:

- någon spricka upptäcks på någon länk
- någon länk blivit deformerad eller på annat sätt skadad
- minvärdet hos någon länks diameter underskrids
- maxvärdet för delningsmättet någonstans överskrids
- kättingen blivit skadad genom upphettning eller har fått svetsstänk

Kätting får ej repareras – den måste bytas ut mot ny originalkätting. Om kättingen önskas längre måste den bytas ut mot en ny som är längre.

Byte av kätting skall utföras fackmässigt av auktoriserad reparatör och kättingen skall uppfylla krav ställda i standard EN 818-7 från följande fabrikat: Chaineries Limousines, Pewag, Thiele eller Rud.

Reparationer

Spaklyftblocket får inte byggas om. Reparationer skall utföras av fackman. Byt ut skadade delar endast mot Powertex original reservdelar. Beställ genom återförsäljaren.

Checklista för regelbunden kontroll (normalt årligen – tätare vid behov)

Dagligen	Årligen	Kontrollpunkter	Kontrollmetod	Observera
Märkning				
X	X	Typskylt	Okulärt	Om skylten är svårläst – byt
Funktion				
X	X	Lyft- och sänkfunktion	Prova utan last	Mjukt snäppande ljud skall höras
-	X	Lyft- och sänkfunktion	Prova med 125% av märklasten utefter en sträcka av min 300 mm	Spaken fungerar lätt. Kothjul och kätting fungerar bra ihop. Bromsen fungerar. Kättingen vrider eller trasslar sig ej. Handkraften på spaken är jämn.
X	X	Omställaren	Manövrering	Går lätt att ställa om
X	X	Frigången	Manövrering	Funktionen
Krokar				
X -	X	Kroköppning	Okulärt Mät	Ser normal ut Se fig 6 och tabell 2
X		Deformation	Okulärt	Ingen synlig deformation
X	X	Kroklagring	Okulärt	Inget onormalt glapp
X -	X	Slitage, sprickor, deformation och korrosion	Okulärt Mät	Inga synliga skador Se fig 6 och tabell 2
X	X	Krokspärrar	Okulärt	Fungerar, fjädern hel
Kätting				
X -	X	Delningen	Okulärt Mät	Ser normal ut. Mät vid tveksamhet Se fig 7 och tabell 3
X -	X	Slitage	Okulärt Mät	Ser felfri ut. Mät vid tveksamhet Se fig 7 och tabell 3
X	X	Deformation	Okulärt	Ingen deformation. Mät vid tveksamhet
X	X	Sprickor m m	Okulärt	Inga sprickor
X	X	Rost	Okulärt	Ingen rost
Hus				
X	X	Huset	Okulärt	Ingen deformation och ingen rost
-	X	Baxningsspaken	Okulärt	Ingen deformation
-	X	Kothjul	Okulärt efter demontering	Inget allvarligt slitage, eller sprickor. Inga brott eller deformationer
-	X	Lagringar	Okulärt, prova	Utan skador, fungerar lätt
-	X	Växel	Okulärt efter demontering	Inget allvarligt slitage eller brott
X	X	Kättingstopp	Okulärt	Skall finnas, fri från deformation
Skrubar				
X	X	Skrubar, muttrar, nitar, sprintar etc.	Okulärt	Får inte saknas. Lösa dras åt. Byt vid behov.
Broms				
-	X	Bromsskiva	Okulärt	Sliten bromsskiva byts
-	X	Bromsskruv	Okulärt	Fri från allvarligt slitage
-	X	Spärrhake och -hjul	Okulärt	Byt slitna delar. Smörj försiktigt med fett.

POWERTEX Lever Hoist PLH-S1 – Spare parts 0,25 t

When ordering spare parts, specify model, WLL, part number and the quantity needed.

When ordering chain, also specify lifting height.

If the load chain has been damaged or worn out the load sheave probably has to be replaced.

POWERTEX Lever Hoist 0,25 t

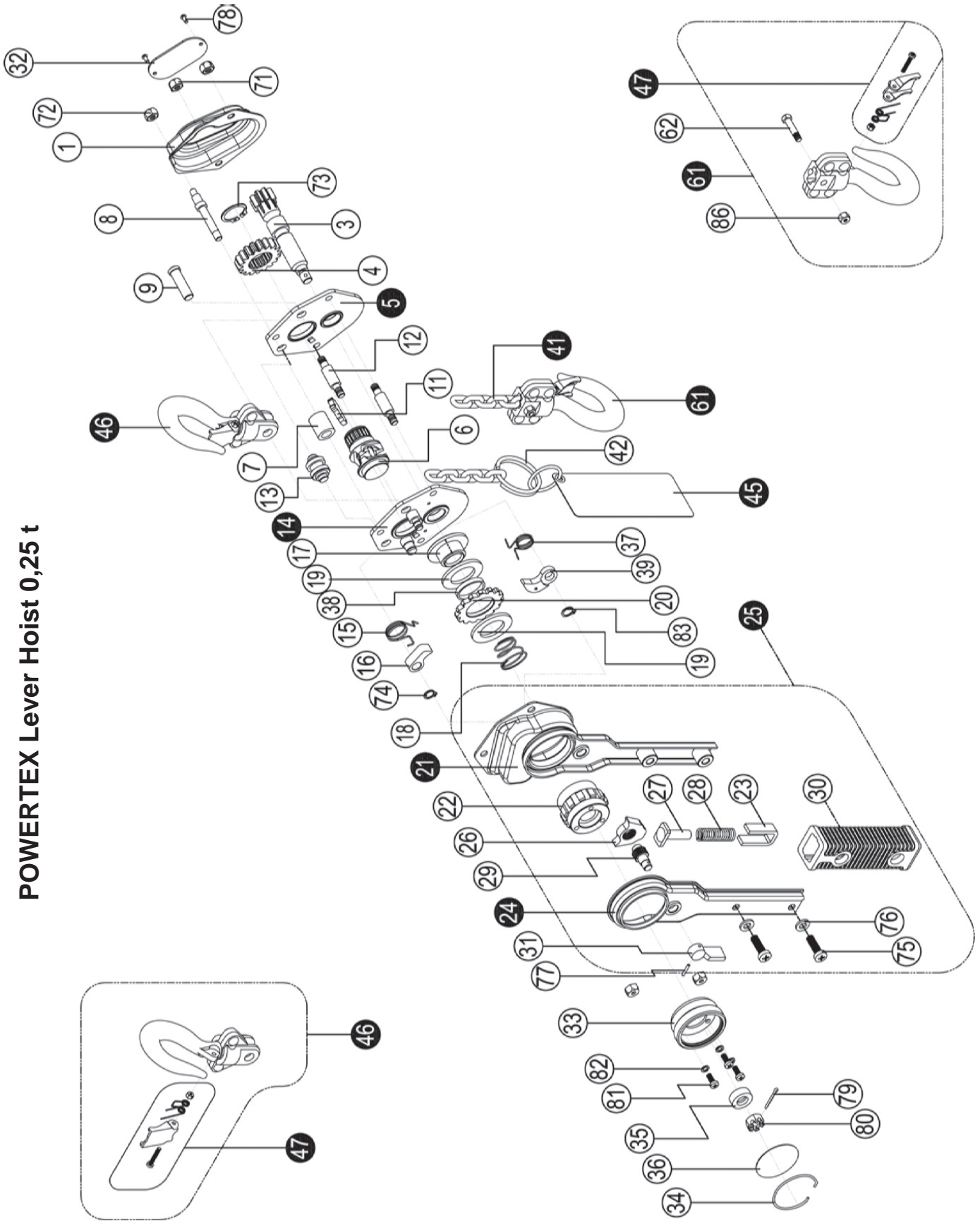

Spare parts list 0,25 t

Pos	Description	0,25 t
1	Gear cover	16.20PLH1511001
3	Drive shaft	16.20PLH1511003
4	Splined gear	16.20PLH1511004
5	Right side plate assy	16.20PLH1511005
6	Load chain sprocket	16.20PLH1511006
7	Bushing	16.20PLH1511007
8	Stay bolt B	16.20PLH1511008
9	Pin for tophook	16.20PLH1511009
10	Bushing B	16.20PLH1511010
11	Chain stripper	16.20PLH1511011
12	Stay bolt A	16.20PLH1511012
13	Guide roller	16.20PLH1511013
14	Left side plate assy	16.20PLH1511014
15	Pawl spring B	16.20PLH1511015
16	Pawl	16.20PLH1511016
17	Disk hub	16.20PLH1711017
18	Free spring	16.20PLH1811018
19	Friction disk	16.20PLH1511019
20	Ratchet disk	16.20PLH1511020
21	Left lever handle assy	16.20PLH1511021
22	Change over gear	16.20PLH1511022
23	Spring seat	16.20PLH1511023
24	Right lever handle assy	16.20PLH1511024
25	Handle assy	16.20PLH1511025
26	Change over pawl	16.20PLH1511026
27	Spring shaft	16.20PLH1511027
28	Change over spring	16.20PLH1511028
29	Selector shaft	16.20PLH1511029
30	Handle rubber grip	16.20PLH1511030
31	Selector lever	16.20PLH1511031
32	Name plate	16.20PLH1511032
33	Hand wheel	16.20PLH1511033
34	Steel wire retainer	16.20PLH1511034
35	Step washer	16.20PLH1511035
36	Hand wheel name plate	16.20PLH1511036
37	Pawl spring	16.20PLH1511037
38	Washer	16.20PLH1511038
39	Pawl	
41	Load Chain	16.20PLH1511041
42	Chain ring	16.20PLH1511042
45	Warning plate assy	16.20PLH1511045
46	Top hook assy	16.20PLH1511046
47	Safety latch assy	16.20PLH1511047
61	Bottom hook assy	16.20PLH1511061
62	Bottom hook pin	16.20PLH1511062
71	Nylon lock nut	16.20PLH1511071
72	Nylon lock nut	16.20PLH1511072
73	Circlip for shaft	16.20PLH1511073
74	Circlip for shaft	16.20PLH1511074
75	Cross head screw	16.20PLH1511075
76	Flat washer	16.20PLH1511076
77	Spring pin	16.20PLH1511077
78	Name plate rivet	16.20PLH1511078
79	Split pin	16.20PLH1511079
80	Hexagon nut	16.20PLH1511080
81	Cross head screw	16.20PLH1511081
82	Light spring washer	16.20PLH1511082
83	Cliclip for shaft	16.20PLH1511083
86	Nylon lock nut	16.20PLH1811086

POWERTEX Lever Hoist PLH-S1 – Spare parts 0,5 – 6 t

When ordering spare parts, specify model, WLL, part number and the quantity needed.

When ordering chain, also specify lifting height.

If the load chain has been damaged or worn out the load sheave probably has to be replaced.

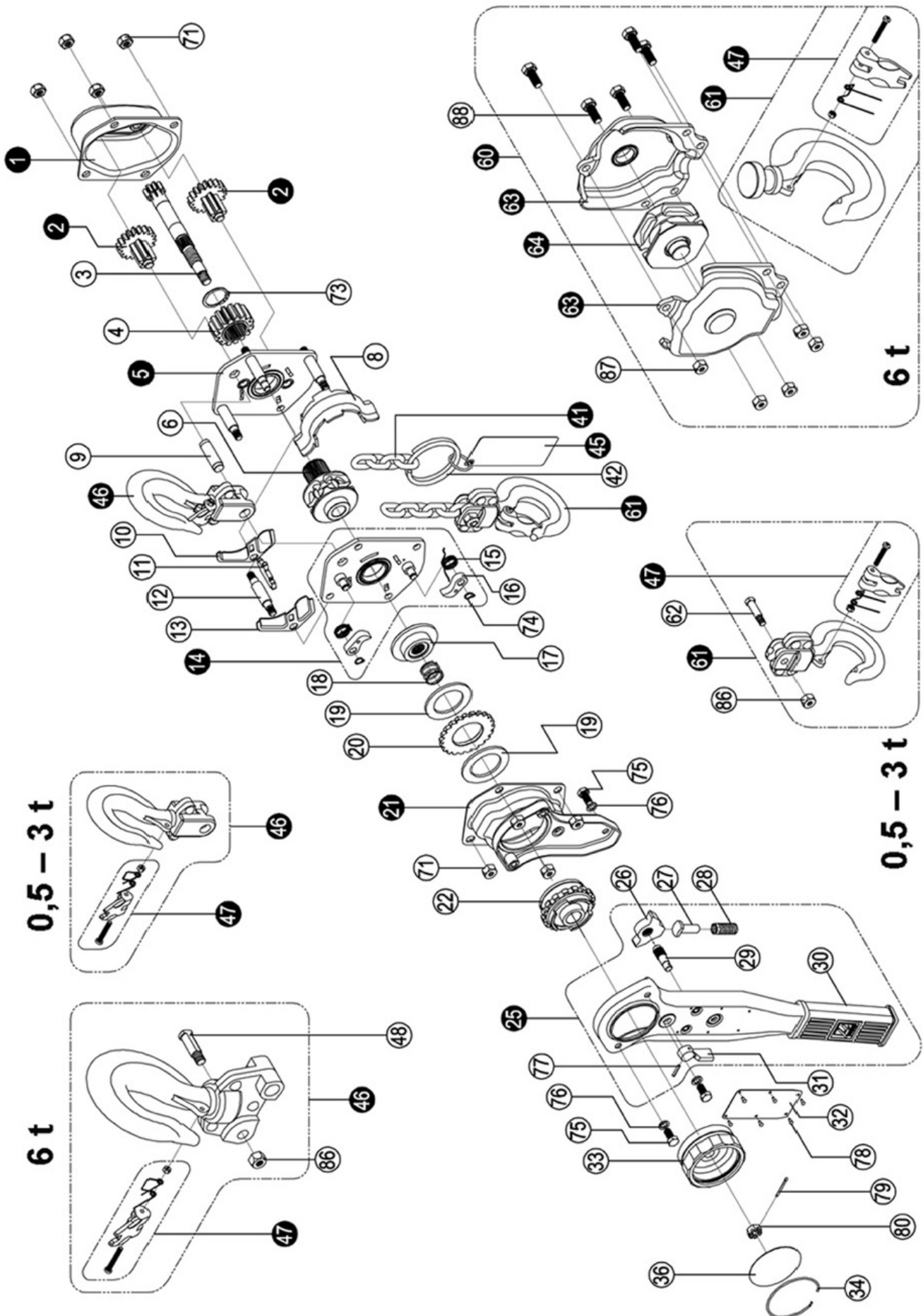

Spare parts list 0,5 – 6 t

Pos	Description	0,5 t	1 t	1,5 t	3 t	6 t
1	Gear cover assy	16.20PLH1512001	16.20PLH1514001	16.20PLH1515001	16.20PLH1517001	16.20PLH1520001
2	Disc gear assy	16.20PLH1512002	16.20PLH1514002	16.20PLH1515002	16.20PLH1517002	16.20PLH1520002
3	Drive shaft	16.20PLH1512003	16.20PLH1514003	16.20PLH1515003	16.20PLH1517003	16.20PLH1520003
4	Splined gear	16.20PLH1512004	16.20PLH1514004	16.20PLH1515004	16.20PLH1517004	16.20PLH1520004
5	Right side plate assy	16.20PLH1512005	16.20PLH1514005	16.20PLH1515005	16.20PLH1517005	16.20PLH1520005
6	Load chain sprocket	16.20PLH1512006	16.20PLH1514006	16.20PLH1515006	16.20PLH1517006	16.20PLH1520006
8	Chain guide	16.20PLH1512008	16.20PLH1514008	16.20PLH1515008	16.20PLH1517008	16.20PLH1520008
9	Top hook shaft	16.20PLH1512009	16.20PLH1514009	16.20PLH1515009	16.20PLH1517009	16.20PLH1520009
10	Chain leader A	16.20PLH1512010	16.20PLH1514010	16.20PLH1515010	16.20PLH1517010	16.20PLH1520010
11	Chain stripper	16.20PLH1512011	16.20PLH1514011	16.20PLH1515011	16.20PLH1517011	16.20PLH1520011
12	Stay bolt B	16.20PLH1512012	16.20PLH1514012	16.20PLH1515012	16.20PLH1517012	16.20PLH1520012
13	Chain leader B	16.20PLH1512013	16.20PLH1514013	16.20PLH1515013	16.20PLH1517013	16.20PLH1520013
14	Left side plate assy	16.20PLH1512014	16.20PLH1514014	16.20PLH1515014	16.20PLH1517014	16.20PLH1520014
15	Pawl spring	16.20PLH1512015	16.20PLH1514015	16.20PLH1515015	16.20PLH1517015	16.20PLH1520015
16	Pawl	16.20PLH1512016	16.20PLH1514016	16.20PLH1515016	16.20PLH1517016	16.20PLH1520016
17	Brake seat	16.20PLH1712017	16.20PLH1514017	16.20PLH1515017	16.20PLH1517017	16.20PLH1520017
18	Free spring	16.20PLH1812018	16.20PLH1514018	16.20PLH1515018	16.20PLH1517018	16.20PLH1520018
19	Friction plate	16.20PLH1512019	16.20PLH1514019	16.20PLH1515019	16.20PLH1517019	16.20PLH1520019
20	Ratchet wheel	16.20PLH1512020	16.20PLH1514020	16.20PLH1515020	16.20PLH1517020	16.20PLH1520020
21	Ratchet wheel cover assy	16.20PLH1512021	16.20PLH1514021	16.20PLH1515021	16.20PLH1517021	16.20PLH1520021
22	Changeover ratchet wheel	16.20PLH1512022	16.20PLH1514022	16.20PLH1515022	16.20PLH1517022	16.20PLH1520022
25	Handle assy	16.20PLH1512025	16.20PLH1514025	16.20PLH1515025	16.20PLH1517025	16.20PLH1520025
26	Changeover pawl	16.20PLH1512026	16.20PLH1514026	16.20PLH1515026	16.20PLH1517026	16.20PLH1520026
27	Spring pin	16.20PLH1512027	16.20PLH1514027	16.20PLH1515027	16.20PLH1517027	16.20PLH1520027
28	Changeover spring	16.20PLH1512028	16.20PLH1514028	16.20PLH1515028	16.20PLH1517028	16.20PLH1520028
29	Selector plate shaft	16.20PLH1512029	16.20PLH1514029	16.20PLH1515029	16.20PLH1517029	16.20PLH1520029
30	Handle rubber grip	16.20PLH1512030	16.20PLH1514030	16.20PLH1515030	16.20PLH1517030	16.20PLH1520030
31	Selector plate	16.20PLH1512031	16.20PLH1514031	16.20PLH1515031	16.20PLH1517031	16.20PLH1520031
32	Name plate	16.20PLH1512032	16.20PLH1514032	16.20PLH1515032	16.20PLH1517032	16.20PLH1520032
33	Hand wheel	16.20PLH1512033	16.20PLH1514033	16.20PLH1515033	16.20PLH1517033	16.20PLH1520033
34	Steel wire retainer	16.20PLH1512034	16.20PLH1514034	16.20PLH1515034	16.20PLH1517034	16.20PLH1520034
36	Hand wheel name plate	16.20PLH1512036	16.20PLH1514036	16.20PLH1515036	16.20PLH1517036	16.20PLH1520036
41	Load Chain	16.20PLH1512041	16.20PLH1514041	16.20PLH1515041	16.20PLH1517041	16.20PLH1520041
42	Chain ring	16.20PLH1512042	16.20PLH1514042	16.20PLH1515042	16.20PLH1517042	16.20PLH1520042
45	Warning plate assy	16.20PLH1512045	16.20PLH1514045	16.20PLH1515045	16.20PLH1517045	16.20PLH1520045
46	Top hook assy	16.20PLH1512046	16.20PLH1514046	16.20PLH1515046	16.20PLH1517046	16.20PLH1520046
47	Safety latch assy	16.20PLH1512047	16.20PLH1514047	16.20PLH1515047	16.20PLH1517047	16.20PLH1520047
48	Top hook pin	-	-	-	-	16.20PLH1520048
60	Bottom hook assy	16.20PLH1512060	16.20PLH1514060	16.20PLH1515060	16.20PLH1517060	16.20PLH1520060
61	Hook assy	16.20PLH1512061	16.20PLH1514061	16.20PLH1515061	16.20PLH1517061	16.20PLH1520061
62	Bottom hook pin	16.20PLH1512062	16.20PLH1514062	16.20PLH1515062	16.20PLH1517062	16.20PLH1520062
63	Bottom hook connector assy	16.20PLH1512063	16.20PLH1514063	16.20PLH1515063	16.20PLH1517063	16.20PLH1520063
64	Idler sheave assy	16.20PLH1512064	16.20PLH1514064	16.20PLH1515064	16.20PLH1517064	16.20PLH1520064
71	Metal lock nut	16.20PLH1512071	16.20PLH1514071	16.20PLH1515071	16.20PLH1517071	16.20PLH1520071
73	Circlip	16.20PLH1512073	16.20PLH1514073	16.20PLH1515073	16.20PLH1517073	16.20PLH1520073
74	Circlip	16.20PLH1512074	16.20PLH1514074	16.20PLH1515074	16.20PLH1517074	16.20PLH1520074
75	Bolt	16.20PLH1512075	16.20PLH1514075	16.20PLH1515075	16.20PLH1517075	16.20PLH1520075
76	Light spring washer	16.20PLH1512076	16.20PLH1514076	16.20PLH1515076	16.20PLH1517076	16.20PLH1520076
77	Spring pin	16.20PLH1512077	16.20PLH1514077	16.20PLH1515077	16.20PLH1517077	16.20PLH1520077
78	Name plate rivet	16.20PLH1512078	16.20PLH1514078	16.20PLH1515078	16.20PLH1517078	16.20PLH1520078
79	Split pin	16.20PLH1512079	16.20PLH1514079	16.20PLH1515079	16.20PLH1517079	16.20PLH1520079
80	Hexagon nut	16.20PLH1512080	16.20PLH1514080	16.20PLH1515080	16.20PLH1517080	16.20PLH1520080
86	Metal lock nut	16.20PLH1512086	16.20PLH1514086	16.20PLH1515086	16.20PLH1517086	16.20PLH1520086
87	Metal lock nut	16.20PLH1512087	16.20PLH1514087	16.20PLH1515087	16.20PLH1517087	16.20PLH1520087
88	Bolt	16.20PLH1512088	16.20PLH1514088	16.20PLH1515088	16.20PLH1517088	16.20PLH1520088

POWERTEX Lever Hoist PLH-S1 – Spare parts 9 t

When ordering spare parts, specify model, WLL, part number and the quantity needed.
When ordering chain, also specify lifting height.

If the load chain has been damaged or worn out the load sheave probably has to be replaced.

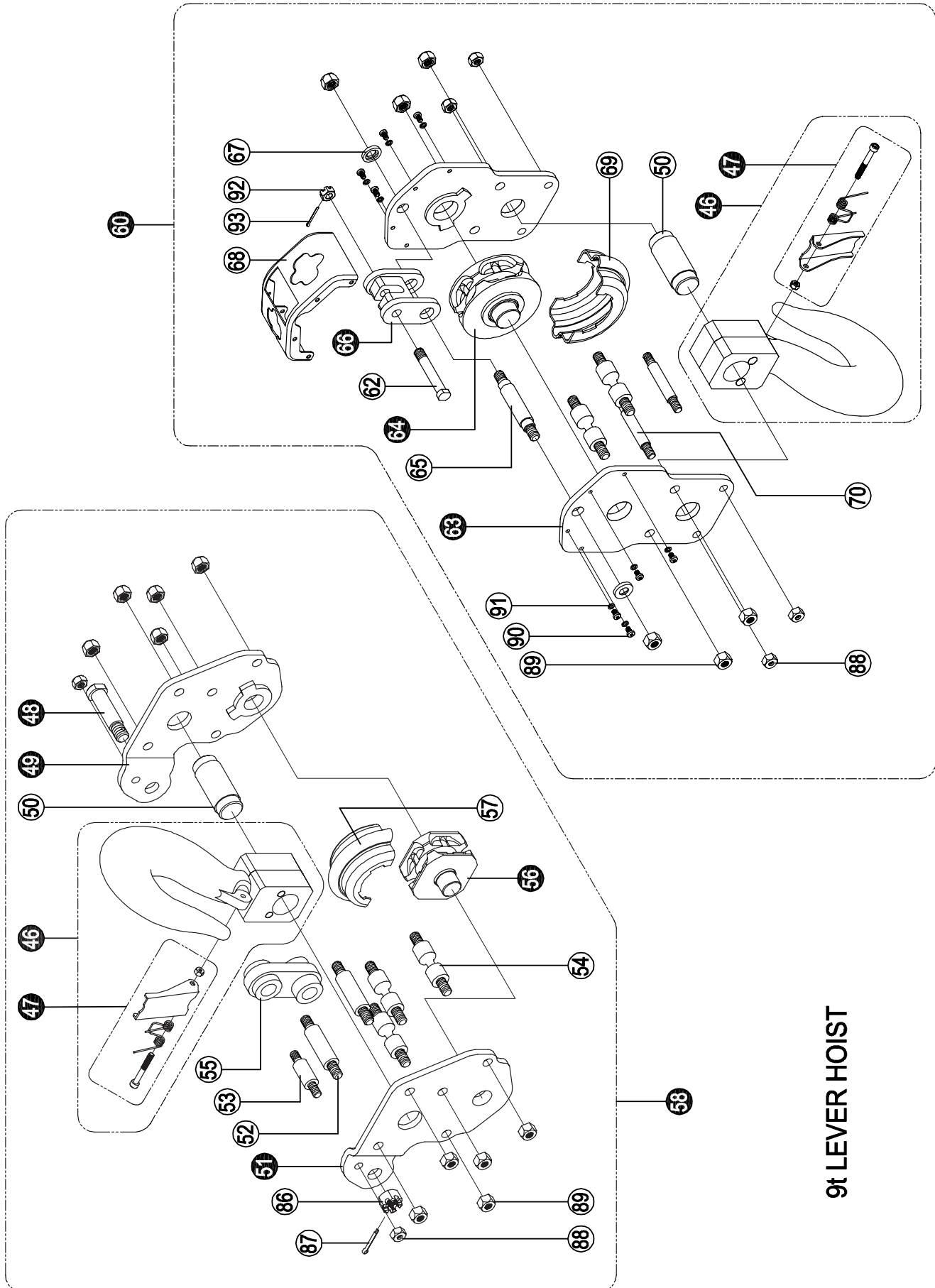

9t LEVER HOIST

Spare parts list 9 t

Pos	Description	9 t
1	Gear cover assy	16.20PLH1522001
2	Disc gear assy	16.20PLH1522002
3	Drive shaft	16.20PLH1522003
4	Splined gear	16.20PLH1522004
5	Right side plate assy	16.20PLH1522005
6	Load chain sprocket	16.20PLH1522006
8	Chain guide	16.20PLH1522008
9	Top hook shaft	16.20PLH1522009
10	Chain leader A	16.20PLH1522010
11	Chain stripper	16.20PLH1522011
12	Stay bolt B	16.20PLH1522012
13	Chain leader B	16.20PLH1522013
14	Left side plate assy	16.20PLH1522014
15	Pawl spring	16.20PLH1522015
16	Pawl	16.20PLH1522016
17	Brake seat	16.20PLH1522017
18	Free spring	16.20PLH1522018
19	Friction plate	16.20PLH1522019
20	Ratchet wheel	16.20PLH1522020
21	Ratchet wheel cover assy	16.20PLH1522021
22	Changeover ratchet wheel	16.20PLH1522022
25	Handle assy	16.20PLH1522025
26	Changeover pawl	16.20PLH1522026
27	Spring pin	16.20PLH1522027
28	Changeover spring	16.20PLH1522028
29	Selector plate shaft	16.20PLH1522029
30	Handle rubber grip	16.20PLH1522030
31	Selector plate	16.20PLH1522031
32	Name plate	16.20PLH1522032
33	Hand wheel	16.20PLH1522033
34	Steel wire retainer	16.20PLH1522034
36	Hand wheel name plate	16.20PLH1522036
41	Load Chain 10x28	16.20PLH1522041
42	Chain ring	16.20PLH1522042
45	Warning plate assy	16.20PLH1520045
46	Hook assy	16.20PLH1522046
47	Safety latch assy	16.20PLH1522047
48	Top hook pin	16.20PLH1522048
49	Beam for hook connector- Right	

50	Hook shaft	
51	Beam for hook connector- Left	
52	Stay bolt A	
53	Short stay bolt	
54	Stay bolt B	
55	Hanger plate	
56	Upper idler sheave assy	
57	Cover for idler sheave	
58	Top hook assy	
60	Bottom hook assy	16.20PLH1522060
62	Bottom hook pin	16.20PLH1522062
63	Plate for hook connector	16.20PLH1522063
64	Bottom idler sheave assy	16.20PLH1522064
65	Bolt	
66	Hanger plate	
67	Spacer washer	
68	Protection cover	
69	Cover for idler sheave	
70	Bolt	
71	Metal lock nut M12	16.20PLH1522071
73	Circlip 42	16.20PLH1522073
74	Circlip 9	16.20PLH1522074
75	Hexagonal head bolt M8x14	16.20PLH1522075
76	Light spring washer	16.20PLH1522076
77	Spring pin 3x18	16.20PLH1522077
78	Name plate rivet 2.5x6	16.20PLH1522078
79	Split pin 2.5x25	16.20PLH1522079
80	Hexagon recess nut M12	16.20PLH1522080
86	Hexagon recess nut M16	16.20PLH1522086
87	Split pin 4x28	16.20PLH1522087
88	Metal lock nut M10	16.20PLH1522088
89	Metal lock nut M12	
90	Cross head screw M5x10	
91	Light spring washer 5	
92	Hexagon recess nut M12	
93	Split pin 2.5x25	



CERTEX Lifting KnowHow app

Download The Lifting KnowHow app'en from the App Store / Google play!

The App has the following features:

- Load charts for different types of lifting slings
- Protractor for measuring sling angles
- Instructions for safe use of a selection of lifting gear
- Built-in gps function that finds the Lifting Solutions Group office closest to your position.
- And a lot more.

The Lifting KnowHow is a unique knowledge transfer programme.



CertMax+

The CertMax+ system is a unique leading edge certification management system which is ideal for managing a single asset or large equipment portfolio across multiple sites. Designed by the Lifting Solutions Group, to deliver optimum asset integrity, quality assurance and traceability, the system also improves safety and risk management levels.



Marking

The POWERTEX Lever Hoist is equipped with a RFID (Radio-Frequency Identification) tag, which is a small electronic device, that consist of a small chip and an antenna. It provides a unique identifier for the block.

The POWERTEX Lever Hoist is **CE** marked

Standard: EN 13157



Warning tag

The warning tag shows some specific and important situations, in which you must pay special attention, when using POWERTEX Chain Blocks and Lever Hoists.



User Manuals

You can always find the valid and updated User Manuals on the web. The manual is updated continuously and valid only in the latest version.

NB! The English version is the Original instruction.

The manual is available as a download under the following link:
www.powertex-products.com/manuals



POWERTEX



The Lifting KnowHow



www.powertex-products.com